

CAST IRON GATE VALVES (NON-RISING STEM) – CLASS 125#

Size range: 1½" to 36"

STANDARDS:	
Design	MSS SP-70
Test	MSS SP-70
Face to Face Dimensions	ANSI B16.10
End Flange Dimensions	ANSI B16.1

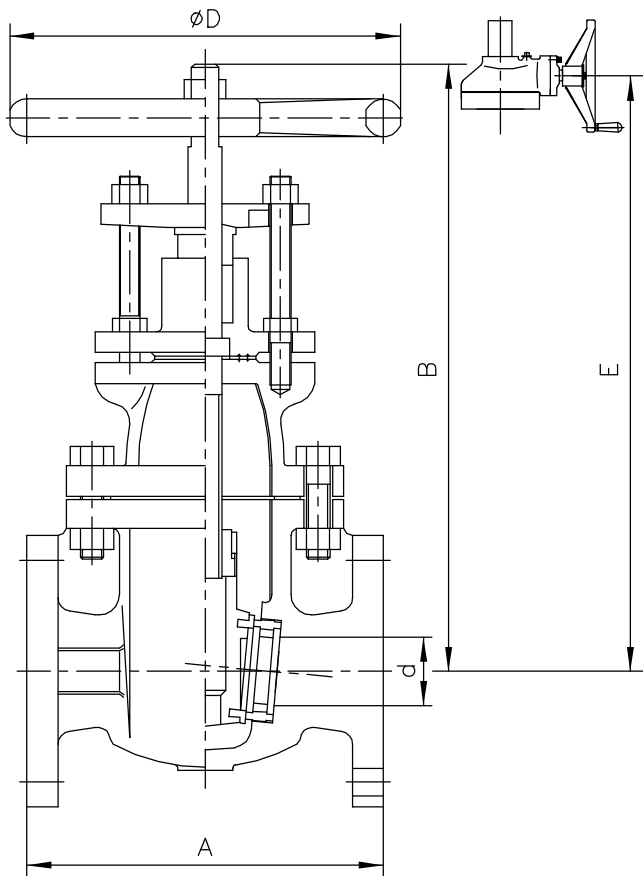

Class 125# Fig No.511125

DIMENSIONS AND WEIGHTS

Size inch	d	A (FF)	B	D	E (GEAR)	Weight (Kg)
1½"	38	165	280	180		15
2"	51	178	313	200		18
2½"	64	191	334	200		25
3"	76	203	370	200		29
4"	102	229	430	260		48
5"	127	254	454	300		65
6"	152	267	550	300		80
8"	203	292	678	350		141
10"	254	330	750	400		202
12"	305	356	880	450		283
14"	337	381	940	508	1027	375
16"	387	406	1080	558	1167	497
18"	438	432	1180	610	1280	606
20"	489	457	1380	640	1480	890
24"	591	508	1460	640	1560	1170
30"	743	610	2140	762	2283	2320
36"	878	711	2385	762	2578	3810

Other Sizes: On request FF: Flat Flanged
 Size 14" and larger the use of gear actuator
 is recommended

AVAILABLE OPTIONS:

STRUCTURE	End, Connection:	Flange Flat Face...
	Seat Rings:	Threaded (Renewable)
	Operation:	Handwheel, Gear, Electric, Pneumatic, Hydraulic...
MATERIALS	Body:	Gray Cast Iron, Ductile Iron...
	Trims:	Cast Bronze, Brass, Stainless Steel...