

GATE VALVES—CLASS 900#

Size range: 2" to 24"

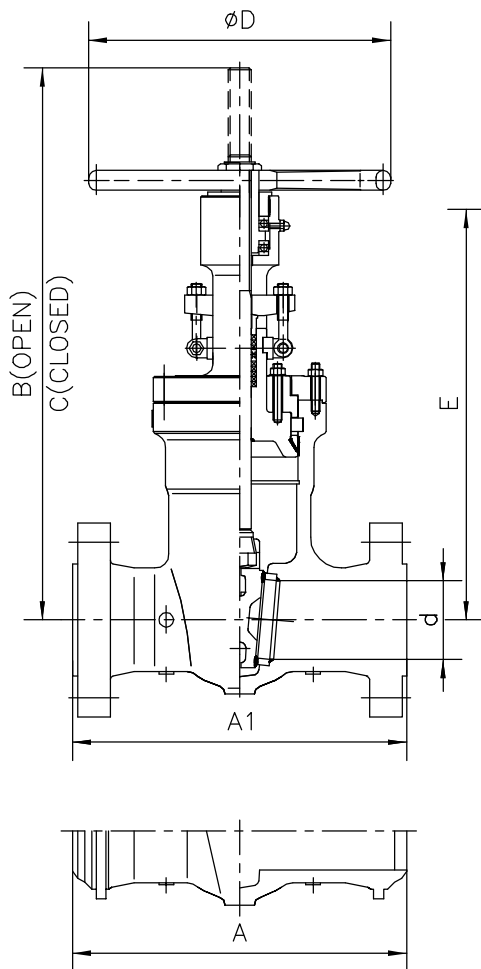

STANDARDS:

Design	ANSI B16.34 & API 600
Test	API 598
Face to Face Dimensions	ANSI B16.10
End Flange Dimensions	ANSI B16.5
Butt-Weld Ends	ANSI B16.25

Class 900# FIG NO. 5900PS

DIMENSIONS AND WEIGHTS

Size inch	d	A1 (RF)	A (BW)	B (OPEN)	C (CLOSE)	D	E	Weight (Kg)(BW)
2"	47	368	216	424	365	300		28
3"	73	381	305	557	477	400		50
4"	98	457	356	667	570	450		80
6"	146	610	508	868	720	560		175
8"	191	737	660	1236	1026		1071	350
10"	238	838	787	1340	1110		1155	475
12"	282	965	914	1487	1217		1257	650
14"	311	1029	991	1620	1310		1385	900
16"	356	1130	1092	1840	1480		1555	1300
18"	400	1219	1219	2050	1645		1730	1900
20"	445	1321	1321	2300	1840		1925	2600
24"	533	1549	1549	2850	2290		2370	4800

Other Sizes: On request

BW: Butt Weld

Sizes 8" and larger the use of gear actuator is recommended

AVAILABLE OPTIONS:

STRUCTURE	End, Connection:	Flange Raised Face, Butt Weld, RTJ...
	Seat Rings:	Threaded (Renewable), Welded
	Operation:	Handwheel, Gear, Electric, Pneumatic, Hydraulic...
MATERIALS	Body:	WCB, WC1, WC6, WC9, LCB, LCC, LC3, C5, C12, CF8, CF8M, CF3, CF3M, CF8C...
	Trims:	13%Cr, 304, 304L, 316, 316L, 321, 347, F-51, Monel...