

WAFLER CHECK VALVES – CLASS 125~2500#

Size range: 2" to 6"

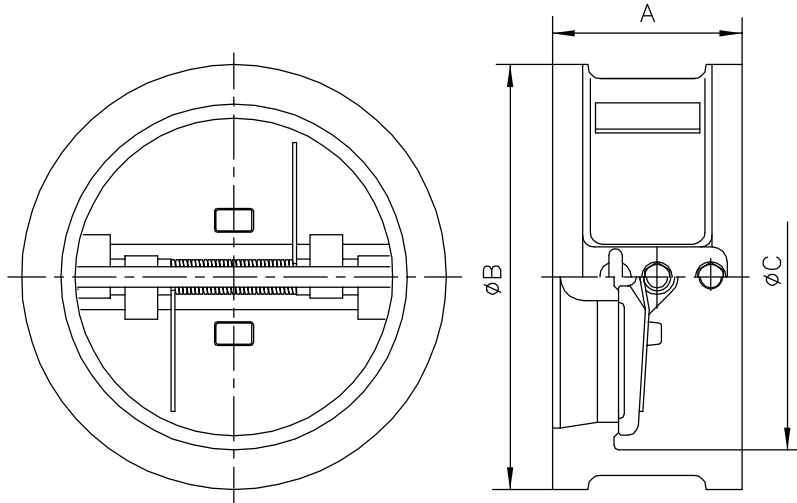

STANDARDS:	
Design	API 6D & API 594
Test	API 598
Face to Face Dimensions	API 594
End Flange Dimensions	ANSI B16.5

DIMENSIONS AND WEIGHTS

Size	CLASS	A	B	C	Weight LBS. KGS
2"	125	2.12	4.12	2.37	5
	PN10	53.8	104.6	60	2.3
	150	2.38	4.12	2.37	5.8
	PN20	60.4	104.6	60	2.65
	250	2.12	4.37	2.37	7.7
	PN25	53.8	111	60	3.5
	300	2.38	4.37	2.37	6.2
	PN50	60.4	111	60	2.8
	600	2.38	4.37	2.37	6.2
	PN100	60.4	111	60	2.8
	900	2.75	5.62	2.75	13.2
	PN150	69.8	142.7	70	6
	1500	2.75	5.62	2.75	14.1
	PN250	69.8	142.7	70	6.4
2500	2.75	5.75	2.75	15.4	
PN420	69.8	146	70	7	
2.5"	125	2.38	4.87	2.87	8.4
	PN10	60.4	123.7	73	3.8
	150	2.62	4.87	2.87	8.4
	PN20	66.5	123.7	73	3.8
	250	2.38	5.12	2.87	10
	PN25	60.4	130	73	4.5
	300	2.62	5.12	2.87	10
	PN50	66.5	130	73	4.5
	600	2.62	5.12	2.87	10
	PN100	66.5	130	73	4.5
	900	3.25	6.5	2.87	15
	PN150	82.5	165.1	73	6.8
	1500	3.25	6.5	2.87	15
	PN250	82.5	165.1	73	6.8
2500	3.25	6.62	2.87	31	
PN420	82.5	168.1	73	14	
3"	125	2.62	5.37	3.5	11
	PN10	66.5	136.5	89	5
	150	2.88	5.37	3.5	12
	PN20	73.1	136.5	89	5.5
	250	2.62	5.87	3.5	13
	PN25	66.5	149	89	6
	300	2.88	5.87	3.5	14
	PN50	73.1	149	89	6.3
	600	2.88	5.87	3.5	14
	PN100	73.1	149	89	6.3
	900	3.25	6.62	3.5	28
	PN150	82.5	168	89	12.7
	1500	3.25	6.87	3.5	29
	PN250	82.5	174.5	89	13.1
2500	3.38	7.75	3.5	45	
PN420	85.8	196.8	89	21	

DIMENSIONS AND WEIGHTS

Size	CLASS	A	B	C	Weight LBS. KGS
4"	125	2.62	6.88	4.5	14
	PN10	66.5	174.7	114.3	6.3
	150	2.88	6.88	4.5	16
	PN20	73.1	174.7	114.3	7.3
	250	2.62	7.12	4.5	17.5
	PN25	66.5	180.8	114.3	7.9
	300	2.88	7.12	4.5	17
	PN50	73.1	180.8	114.3	7.7
	600	3.12	7.62	4.5	24
	PN100	79.2	193.5	114.3	10.9
	900	4	8.12	4.5	36
	PN150	101.6	206.2	114.3	16.3
	1500	4	8.25	4.5	42
	PN250	101.6	209.5	114.3	19
2500	4.12	9.25	4.5	90	
PN420	104.6	234.9	114.3	41	
5"	125	3.25	7.75	5.56	19
	PN10	82.5	196.8	141.2	8.6
	150	3.37	7.75	5.56	20.5
	PN20	85.6	196.8	141.2	9.3
	250	3.25	8.5	5.56	29
	PN25	82.5	215.9	141.2	13.2
	300	3.37	8.5	5.56	29
	PN50	85.6	215.9	141.2	13.2
	600	4.12	9.5	5.56	49
	PN100	104.6	241.3	141.2	22.2
	125	3.75	8.75	6.62	27
	PN10	95.2	222.2	168.1	12.2
	150	3.88	8.75	6.62	29
	PN20	98.5	222.2	168.1	13.1
250	3.75	9.88	6.62	40	
PN25	95.2	250.9	168.1	18.1	
300	3.88	9.88	6.62	42	
PN50	98.5	250.9	168.1	19	
600	5.38	10.5	6.62	70	
PN100	136.6	266.7	168.1	31.8	
900	6.25	11.37	6.62	115	
PN150	158.7	288.8	168.1	52.2	
1500	6.25	11.12	6.62	125	
PN250	158.7	282.4	168.1	57	
2500	6.25	12.5	6.62	180	
PN420	158.7	317.5	168.1	82	